



FM-4W 25 Technical Data.

4-way reach truck



Residual capacities/Load centre.

Hyd. Fork adjustment			
2500			
2400			
2300	o	o	o
2200			
2100			
2000			
	400	500	600

Manual Fork adjustment			
2500	o	o	
2400			o
2300			
2200			
2100			
2000			
	400	500	600

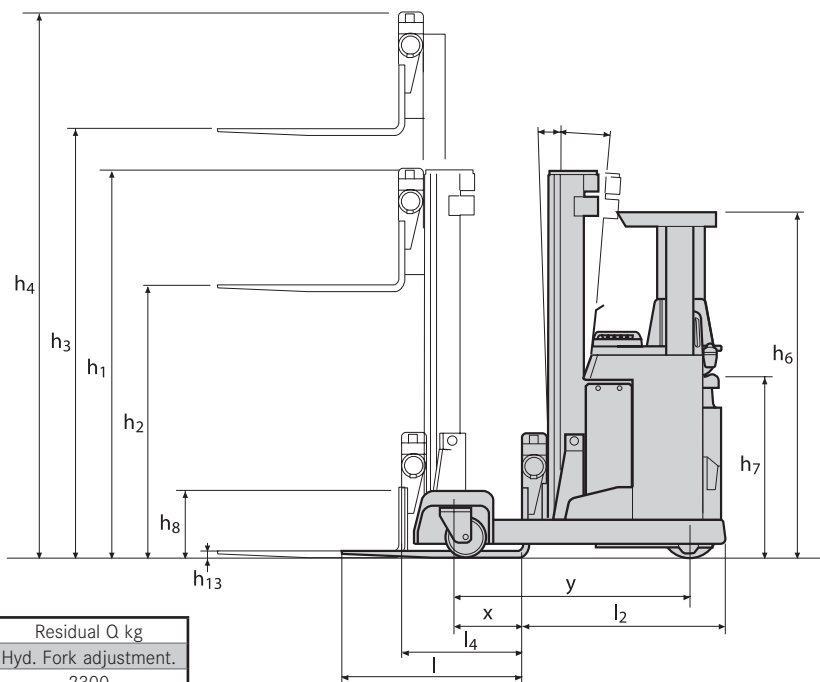
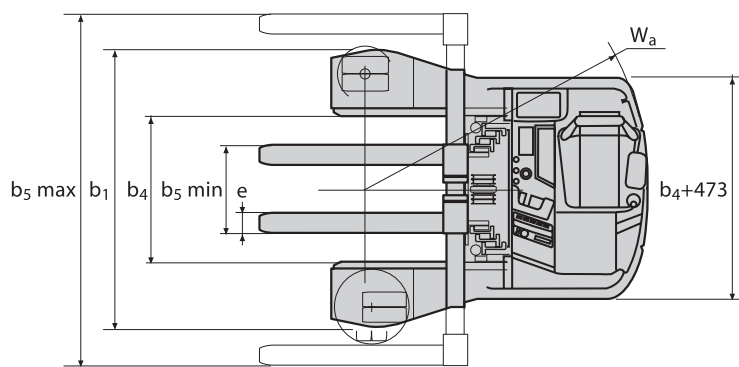

Mast table.

h_1	h_2	h_3	h_4	Residual Q kg	
				Mech. Fork adjustment.	Hyd. Fork adjustment.
2340	1623	4500	5210	2400	2300
2440	1723	4800	5510	2350	2300
2640	1923	5400	6110	2200	2200
2957	2240	6350	7060	1900	1900
3190	2473	7050	7760	1700	1700
3357	2640	7550	8260	1600	1600
3523	2806	8050	8760	1500	1500
3673	2956	8500	9210	1450	1450
3840	3123	9000	9710	1350	1350

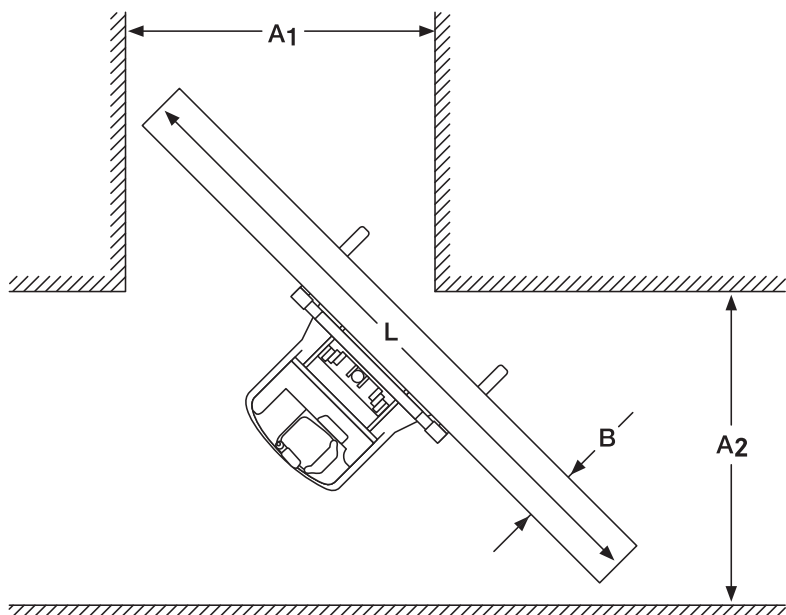

Aisle A1 m	Main aisle A2 m			
	Load length L			
	4 m	6 m	8 m	10 m
2.0	2.0	3.3	4.8	6.4
2.2	2.0	3.0	4.5	6.1
2.4	2.0	2.7	4.3	5.8
2.6	2.0	2.5	4.0	5.5
2.8	2.0	2.3	3.8	5.3
3.0	2.0	2.2	3.5	5.0
3.2			3.3	4.8
3.4			3.2	4.6
3.6			3.0	4.4
3.8			2.9	4.1
4.0				3.9
4.2				3.8
4.4				3.6

This specification sheet to VDI Guidelines 2198 only gives the technical figures for the standard truck.
Different tyres, masts, additional equipment etc. could give different figures.

Characteristics	1.1	Manufacturer			STILL
	1.2	Manufacturer's model designation			FM-4W 25
	1.3	Drive (electric, diesel, petrol, LPG)			Electric
	1.4	Operation (hand, pedestrian, stand on, rider seated)			Rider seated
	1.5	Capacity/load	Q	kg	2500
	1.6	Load centre	c	mm	600
	1.8	Load distance	x	mm	533*
	1.9	Wheel base	y	mm	1660
	Weights	2.1	Truck weight inc. Battery		kg
2.3		Axle load unladen/Driver at load end		kg	2550/2250
2.4		Axle load forks forward, laden, Driver at load end		kg	950/6350
2.5		Axle load forks back, laden, Driver at load end		kg	2350/4950
Wheels chassis		3.1	Tyres (rubber, polyurethane, pneumatic)		
	3.2	Tyre size, driver's end		mm	Ø 350 x 140
	3.3	Tyre size, load end, load wheel/swivel castor		mm	Ø 285 x 110 / 260 x 85
	3.5	Number of wheels (x=driven) Load end/driver's end			1x /4
	3.6	Track width, driver's end	b ₁₀	mm	0
	3.7	Track width, Load end	b ₁₁	mm	1470
	Basic dimensions	4.1	Mast/carriage tilt, forward/back		°
4.2		Height, mast lowered	h ₁	mm	See table
4.3		Free lift	h ₂	mm	See table
4.4		Lift	h ₃	mm	See table
4.5		Height, mast raised	h ₄	mm	See table
4.7		Height over overhead guard (cab)	h ₆	mm	2155
4.8		Seat height/platform height	h ₇	mm	1050/1120
4.10		Height of straddle arms or load wheels	h ₈	mm	420
4.19		Overall length	l ₁	mm	2548*
4.20		Length including fork backs	l ₂	mm	1398*
4.21		Overall width	b ₁ /b ₂	mm	1765/1260
4.22		Fork dimensions	s/e/l	mm	45/125/1150
4.24		Fork carriage width	b ₃	mm	1500
4.25		Fork adjustment min/max		mm	556/1546 (556/2216)
4.26		Width between straddle arms/load surfaces	b ₄	mm	924
4.28		Reach	l ₄	mm	813*
4.32		Floor clearance, centre of wheel-base	m ₂	mm	47
4.33	Working aisle width with 1000 x 1200 pallet crossways	A _{st}	mm	2895*	
4.34	Working aisle width with 800 x 1200 pallet lengthways	A _{st}	mm	2913*	
4.35	Turning radius	W _a	mm	1935	
4.37	Length over straddle arms	l ₇	mm	2137	
Performance	5.1	Travel speed laden/unladen		km/h	13.2/14.0
	5.2	Hoist speed laden/unladen		m/s	0.26/0.51
	5.3	Lowering speed laden/unladen		m/s	0.55/0.55
	5.4	Reach speed laden/unladen		m/s	0.2/0.2
	5.8	Max. gradeability laden/unladen		%	6.1/9.6
	5.10	Service brake			generator/hyd.-mech.
Motor	6.1	Drive motor, rating S2 = 60 min		kW	7.5
	6.2	Hoist motor, rating at S3 = 15%		kW	14
	6.3	Battery to IEC 254-2; A, B, C, No			IEC 254-2, C
	6.4	Battery voltage, rated capacity C5		V/Ah	48/560
	6.5	Battery weight +/- 5% (depends on make)		kg	939-1306
Misc	8.1	Drive controller			Pulse/stepless
	8.2	Working pressure for attachments		bar	150
	8.4	Sound level at driver's ear		dB(A)	70

* depends on battery size

	Manufacturer	STILL
	Manufacturer's model designation	FM-4W 25
Driver's compartment	Driver's seat with longitudinal adjustment	●
	Comfortable seat with hydraulic damping	●
	Tilting seat, inclination 15°	●
	Tilting head rest	○
	Driver's seat with heater	○
	Head cushion on overhead guard leg	●
	Display: active operating states and service instructions	●
	Four driving profiles selectable by driver	●
Steering	Full electric steering 360°	●
	Control unit adjustable for height, inclination and length	●
	Mini-steering wheel with adjustable height arm rests	○
	Direct spline mounted steer motor (maintenance free)	●
	Drive wheel, steered	●
	Load wheel reversible and smoothly positioned	●
Mast	Triplex clearview mast with free lift	●
	Mast transition damping	●
Fork carriage	Manual fork adjustment with mast tilt, adjustment range 560 - 1550 mm	●
	Manual fork adjustment, Adjustment range 560 - 2220 mm	○
	Hydraulic fork adjustment, Adjustment range 560 - 1550 mm	○
	Hydraulic fork adjustment, Adjustment range 560 - 2220 mm	○
	Creep speed with fork carriage raised	○
	Fork extensions	○
Hydraulics	Operation through four single levers	●
	Operation through joystick	○
	Noise optimised hydraulic pump	●
	Auxiliary hydraulics	○
	Proportional valve technology for particularly sensitive movements	●
Separate parameter setting option for the hydraulic functions	●	
Drive	Three phase drives	●
	Best energy utilisation thanks to spur bevel gear transmission	●
	Treaded drive wheel	○
Brake	Hydraulic load wheel brake	●
	Electromagnetic disc brake as a service and parking brake	●
Central controller	CAN bus Technology	●
	Programming facilities for the drive, acceleration and retardation figures	●
	Central Service and Diagnostics interface	●
Battery	Battery extracted using mast reach	●
	Battery changing using hoist	●
	Battery charging to side using roller track	○
Additional equipment	Weather protection cab	○
	Cold store version	○
	Writing surface	○
	Preparation for data terminal	○
	Load indicator with height indicator	○
	Working spotlight	○
	Warning lamps	○
	Intermediate hoist limiters	○
	Height indicator	○
	Card reader for access authorisation	○
Radio with CD/MP3-Player	○	

● Standard ○ Option

Standard equipment.

The FM-4W 25 four-way truck is a universal unit, which is especially suitable for transporting long products and putting them into stock, as well as normal pallets and containers. Thanks to its four-way design it allows the economical utilisation of storage space with minimal working aisle widths.

Driver's compartment.

- Adjustable steering wheel position with fore and aft seat adjustment allows a comfortable working position.
- Comfort seat features hydraulic damping adjustable to the driver's body weight as well as a tilt function (up to 15°). Seat contour shaped to give plenty of untiring support. For added safety the truck can only be driven if the foot switch is depressed.
- The clear view mast with good all round visibility and optimised view through the overhead guard give the driver a very clear optimum overview.
- Control is through four ergonomic levers.
- Comfortable, upholstered arm rest provides supports whilst operating the truck.
- A display panel for the active operating states and service information shows: ready state, driving direction, position of the steered load wheel, parking brake status, steering status, inching, operating hours, battery state of charge.
- The FM-4W 25 has four drive categories for the driver to choose from in order to control the truck's acceleration, deceleration, plugging and travel speed.
- Adjustable height operating panel for improved ergonomics.
- Various storage facilities for documents, etc.

Electric steering.

- The steering wheel has fully electric actuation, i.e. no high-maintenance mechanical link with the steer motor.
- Reduced energy consumption due to the steering electronics only being activated when the steering wheel is moved.
- Minimal movement forces give precise, light and easy steering.
- High turnround of goods and driving comfort due to 360° unlimited steering.
- Steering wheel adjustable for height, rake and length for improved ergonomics.
- Change of drive direction through 90°. For diagonal travel the load wheel can be positioned smoothly.

Mast.

- Triplex clear view mast with mast tilt and free lift as standard for utilisation of space right up to the roof.
- The nested I-beam section mast with integral hoist cylinders and hoist chains running behind them gives a very clear view.
- Manual or optional hydraulic fork adjustment up to 2250 mm.

Hydraulics.

The proportional control valve fitted as standard allows particularly sensitive movements.

- Operating speeds for lifting, lowering and reach.
- Stepless control of movements improves safety of operation.
- Powerful three-phase drives.

Drive unit.

The truck will start smoothly and accelerate smoothly to maximum speed.

- The three-phase motor does not rotate when steering, preventing stressed cable connections.
- Monitoring equipment avoids defects and makes it possible to plan for down time.
- Integral current and temperature sensors.
- Malfunction monitoring.
- Highly efficient energy use thanks to the spur bevel gear transmission.

Brake.

The brake system consists of an electromagnetic and a hydraulic brake. The electromagnetic disc brake acts on the motor shaft and serves as a parking brake, while the hydraulic brake acts on the load wheel.

Central control.

- The design of the circuitry and controller (in conjunction with CAN bus technology) provides a very high standard of safety.
- All speeds can be programmed: Main hoist lift/lower, travel speed forwards/reverse, acceleration and deceleration, inching speed, mast reach, mast tilt and mast side-shift, plus the ramp functions when reaching forwards and backwards.
- Connection of diagnostic system through an easily accessible central diagnostic plug.

Battery.

- Battery extracted using mast reach.
- For multi-shift use, the battery can be changed using a hoist or an optional battery roller track.

Safety.

The truck is built in compliance with the EC guideline 98/37/EC and carries the CE Symbol. STILL is certified to ISO 9001.



Наши контакты

ООО "Торговый Дом Техника для Склада"

Москва: Нагорный проезд, дом № 10 А

Телефон: +7 (495) 545-31-74

Санкт-Петербург: ул. Боровая, д. 44, лит. А

Телефон: +7 (812) 303-80-30

Более подробную информацию Вы найдете на сайте:

www.tdtds.ru